

# SERVO VALVES

## 3-STAGE FLOW CONTROL

### 79 SERIES

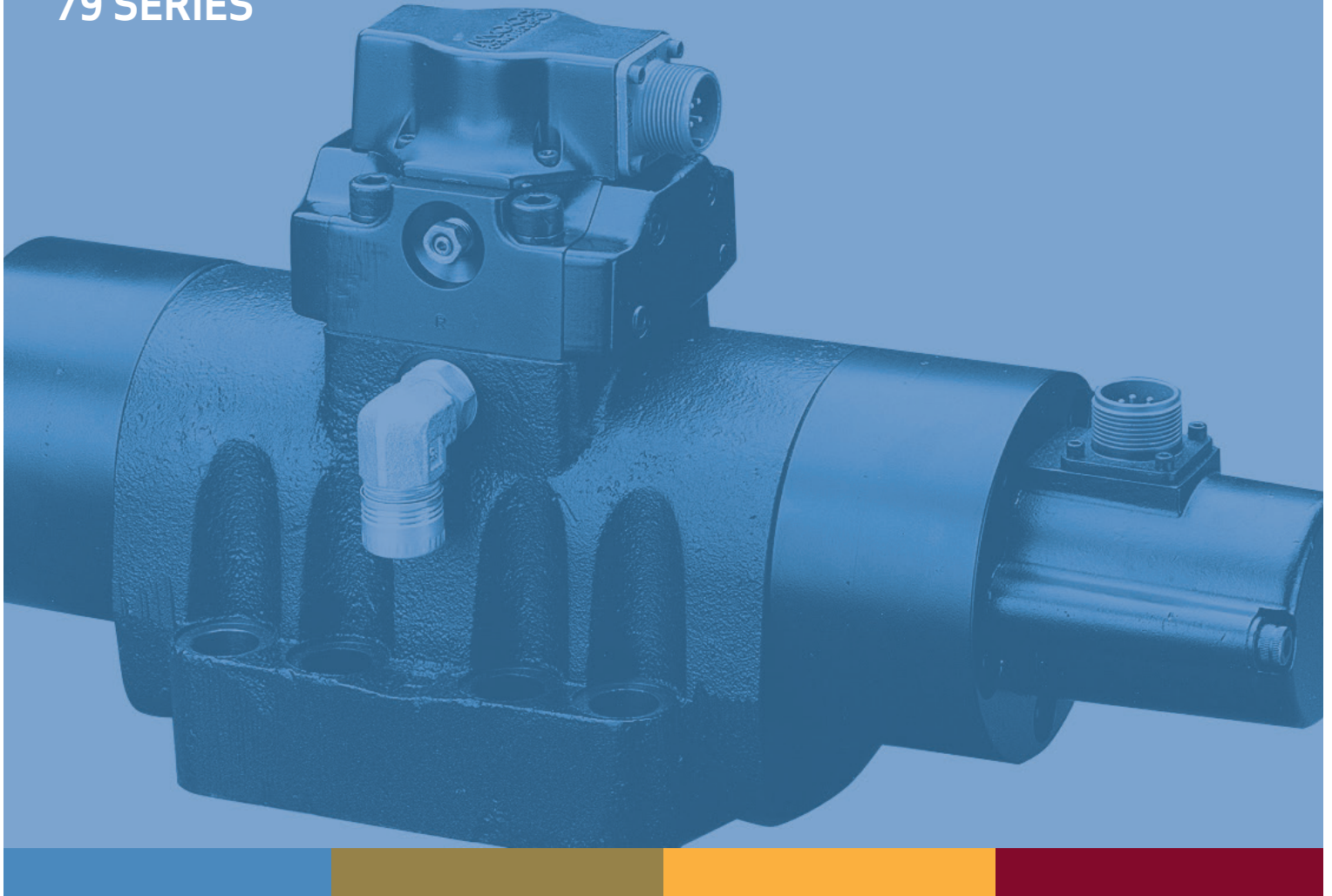

Rev. K, December, 2011

FOR DEPENDABLE, LONG LIFE OPERATION WHERE  
POSITION, SPEED, PRESSURE OR FORCE CONTROL  
SYSTEMS HAVE HIGH DYNAMIC RESPONSE  
REQUIREMENTS

# 79 SERIES THREE STAGE SERVO VALVES

## 79 SERIES SERVO VALVES

The 79 Series flow control servo valves are throttle valves for 3 and preferably 4-way applications. These three stage servo valves were developed for applications that require high flow rates and high performance. The 79 series covers the range of rated flow from 30 to 200 gpm at 1,000 psi valve drop. These valves are offered with 76X Series pilot valves, in either

Standard, High, or Very High performance configurations.

These valves are suitable for electrohydraulic position, speed, pressure or force control systems with high dynamic response requirements.

### Principle of operation

An electrical command signal (set point, input signal) is applied to the external control

amplifier which drives a current through the pilot valve coils. The pilot valve produces differential pressure in its control ports. This pressure difference results in a pilot flow which causes main spool displacement.

The position transducer, which is excited via an oscillator, measures the position of the main spool (actual value, position voltage). The signal

then is demodulated and fed back to the control amplifier where it is compared with the command signal. The control amplifier drives the pilot valve until the error between command signal and feedback signal is zero. Thus, the position of the main spool is proportional to the electrical command signal.

## VALVE FEATURES

- Electrical feedback on the main spool for low hysteresis and excellent linearity
- Optional external pilot supply and return connections
- High spool control forces
- High dynamics
- Rugged, long-life design
- High resolution, low hysteresis
- Completely set-up at the factory
- Excellent null stability

The actual flow is dependent upon electrical command signal and valve pressure drop. The flow for a given valve pressure drop can be calculated using the square root function for sharp edge orifices.

The flow value Q calculated in this way should not exceed an average flow velocity of 100 ft/s in ports P, A, B and T.

$$Q = Q^N \sqrt{\frac{\Delta p}{\Delta p^N}}$$

- Q [gpm] = calculated flow
- $Q^N$  [gpm] = rated flow
- $\Delta p$  [psi] = actual valve pressure drop
- $\Delta p^N$  [psi] = rated valve pressure drop

If large flow rates with high valve pressure drops are required, an appropriate higher pilot pressure has to be chosen to overcome the flow forces. An approximate value can be calculated as follows:

$$p^* \geq 5.6 \cdot 10^{-2} \cdot \frac{Q}{A^k} \cdot \sqrt{\Delta p}$$

- Q [gpm] = max. flow
- $\Delta p$  [psi] = valve pressure drop with Q
- $A^k$  [in<sup>2</sup>] = spool drive area
- $p^*$  [psi] = pilot pressure

The pilot pressure  $p^*$  has to be at least 215 psi above the return pressure of the pilot stage.



This catalog is for users with technical knowledge. To ensure that all necessary characteristics for function and safety of the system are given, the

user has to check the suitability of the products described here. In case of doubt, please contact Moog Inc.

79 SERIES  
GENERAL TECHNICAL DATA

**Operating Pressure**

**Main Stage\***

Ports P, A and B  
with X internal up to 5,000 psi with High Pressure Pilot  
with X external up to 5,000 psi  
Port T with Y internal up to 3,000 psi  
Port T with Y external up to 5,000 psi  
Pilot valve (76X series)\*

Ports P, A and B up to 5,000 psi  
Port T up to 3,000 psi

**Temperature Range**

Fluid 0°F to 180°F  
Ambient 0°F to 180°F

**Seal Material**

Viton, others on request

**Operating Fluid**

Mineral oil based hydraulic fluid  
(to DIN 51524), others on request

Recommended viscosity 60-450 SUS @ 100°F

**Class of Cleanliness:**

The cleanliness of the hydraulic fluid greatly effects the performance (spool positioning, high resolution) and wear (metering edges, pressure gain, leakage) of the valve.

**Recommended Cleanliness Class**

For normal operation ISO 4406 < 14/11

For longer life ISO 4406 < 13/10

**System Filtration**

Pilot valve: High pressure filter (without bypass, but with dirt alarm) mounted in the main flow and if possible, directly upstream of the servo valve.

Main stage: High pressure filter as for the pilot stage. In combination with a fast regulating VD-pump, a bypass filter is possible.

**Filter Rating recommended**

For normal operation  $\beta_{10} \geq 75$  (10  $\mu\text{m}$  absolute)

For longer life  $\beta_5 \geq 75$  (5  $\mu\text{m}$  absolute)

**Installation Options**

Any position, fixed or moveable.

**Vibration**

30 g, 3 axes

**Weight**

**Shipping Plate**

Delivered with an oil sealed shipping plate.

\* Maximum special order is 5,000 psi

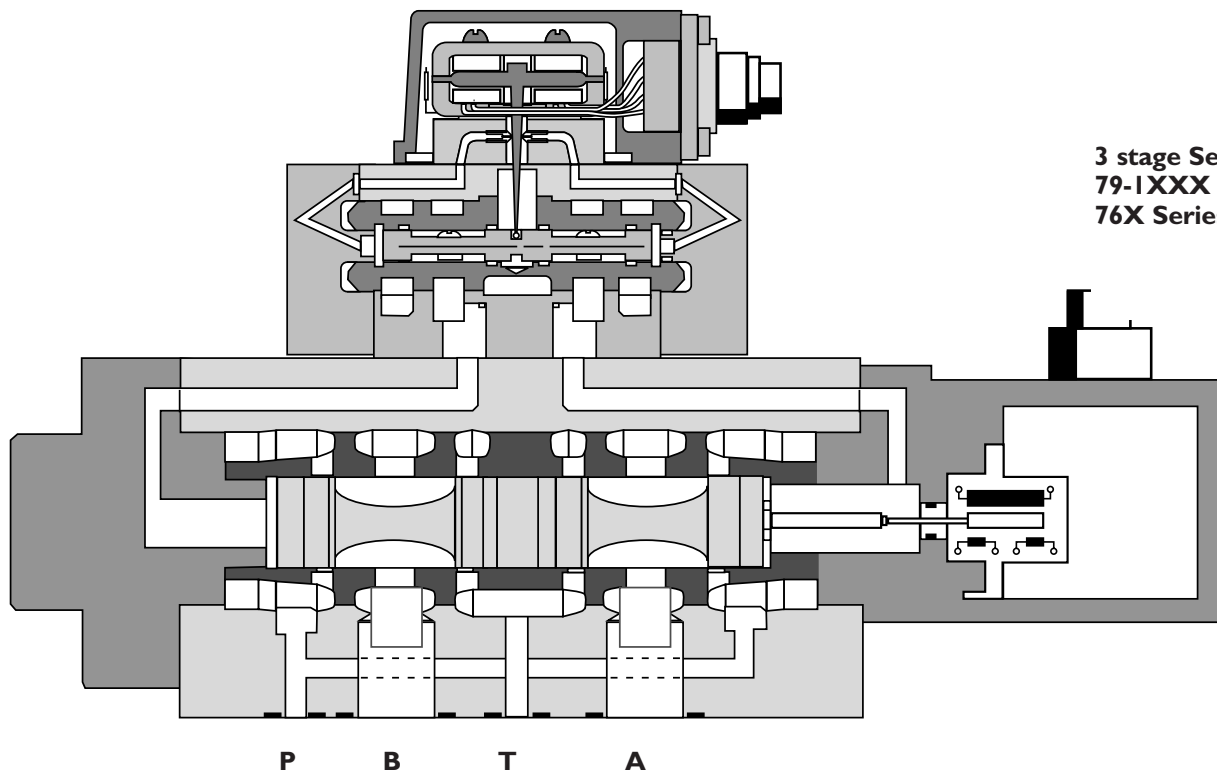

**3 stage Servo Valve  
79-1XXX Series with a  
76X Series pilot valve**

79-1XXX SERIES  
TECHNICAL DATA

**Model . . . Type**  
**Mounting Pattern**  
**Valve Body Version**

ISO, but X and Y do not correspond to ISO

**79-1XXX**

ISO 10372-06-05-0-92

4-way

3-stage with spool-bushing assembly

2-stage, 76X series

X and Y

24 lbs [10.9 kg]

**Pilot Valve**

**Pilot Connection**

Optional, internal or external

Mass

**Rated Flow**

(± 10%) at  $\Delta p^N = 1,000$  psi [gpm]

30

60

**Response Time\***

for 0 to 100% stroke [ms]

14

14

**Threshold\***

[%]

< 0.5%

**Hysteresis\***

[%]

< 1.0%

**Null Shift**

with  $\Delta T = 50^\circ C$  [%]

< 2.5%

**Null Leakage Flow\***

total, max. [gpm]

0.8

1.6

Main Spool Stroke [in]

.075

Main Spool Drive Area [in<sup>2</sup>]

0.442

\* measured at 3,000 psi pilot or operating pressure, respectively, and fluid viscosity 32 mm<sup>2</sup>/s

**Typical Characteristic**

**Curves** measured at 3,000 psi pilot or operating pressure, respectively, and fluid kinematic viscosity of 32 mm<sup>2</sup>/s.

**Set-up and Operation**

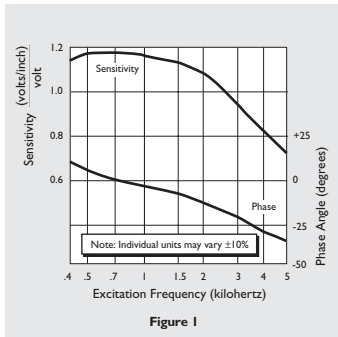

**Frequency Response**

for valves with different rated flows and different pilot valves

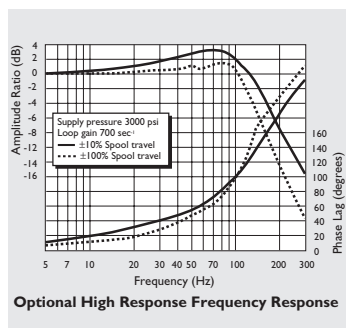
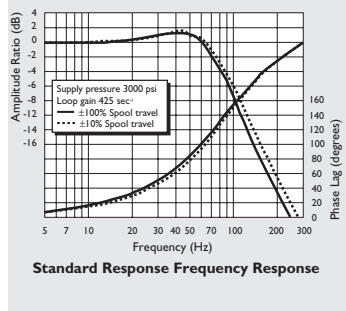

**Valve Flow Diagram**

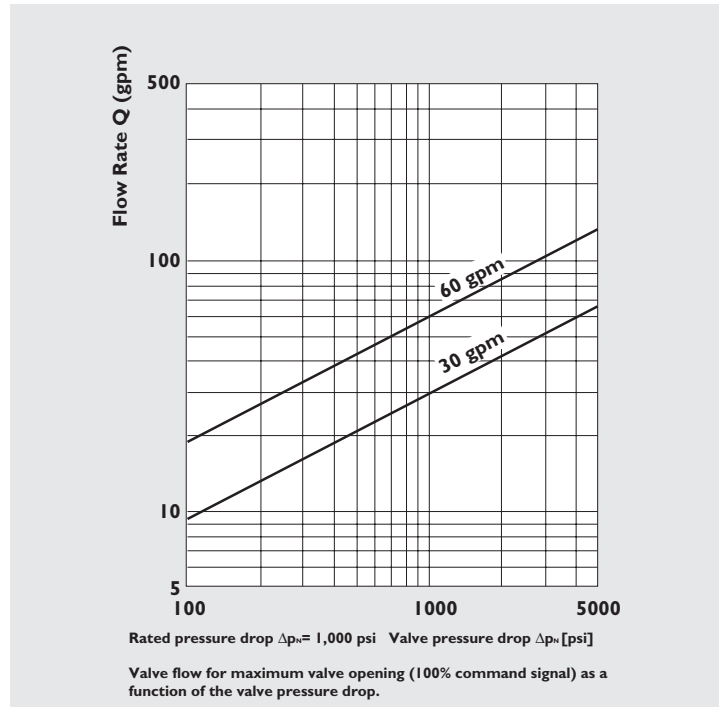

# 79-2XXX SERIES TECHNICAL DATA

**Model . . . Type**  
**Mounting Pattern**  
**Valve Body Version**

## 79-2XXX

Moog Standard

4-way

3-stage with spool-bushing assembly

2-stage, 76X series

X and Y

35.5 lbs. [16.1 kg]

**Pilot Valve**

**Pilot Connection** Optional, internal or external

Mass

**Rated Flow** ( $\pm 10\%$ ) at  $\Delta p^N = 1,000$  psi [gpm]

100

200

250

**Response Time\*** for 0 to 100% stroke Standard [ms]

15

15

15

High Response [ms]

6

6

6

**Threshold\*** [%]

< 0.5%

**Hysteresis\*** [%]

< 0.5%

**Null Shift** with  $\Delta T = 50^\circ C$  [%]

< 2.0%

**Null Leakage Flow\*** total, max. [gpm]

2.5

2.5

2.5

Main Spool Stroke [in]

0.130

Main Spool Drive Area Standard [in<sup>2</sup>]

1.107

High Response [in<sup>2</sup>]

0.442

\* measured at 3,000 psi pilot or operating pressure, respectively, and fluid viscosity 32 mm<sup>2</sup>/s

**Typical Characteristic Curves** measured at 3,000 psi pilot or operating pressure, respectively, and fluid kinematic viscosity of 32 mm<sup>2</sup>/s.

**Frequency Response** for valves with different rated flows and different pilot valves.

### Standard Valves

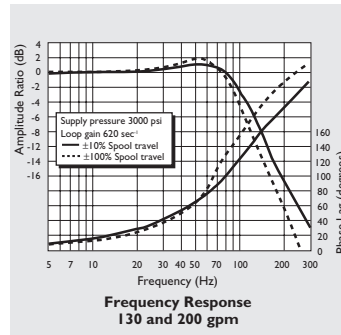
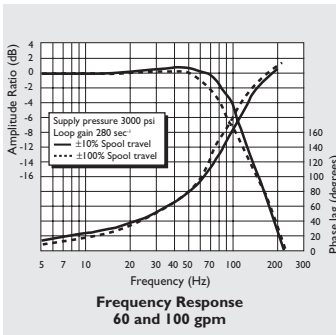

### High Response Valves

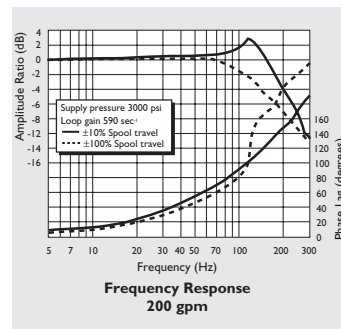
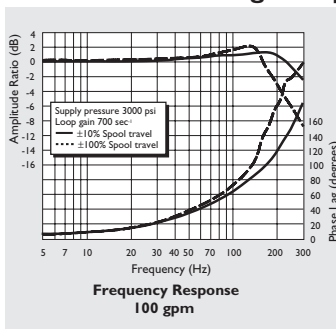

### Valve Flow Diagram

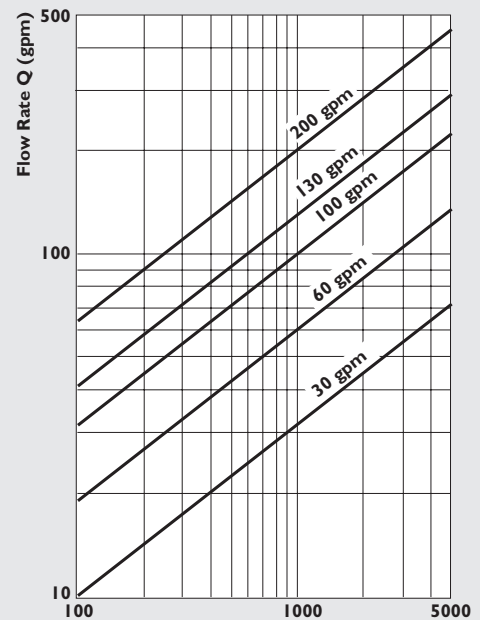

Valve flow for maximum valve opening (100% command signal) as a function of the valve pressure drop.

79-1XXX SERIES  
 INSTALLATION DRAWINGS WITH  
 PILOT VALVES 76X SERIES

The mounting Manifold must conform to ISO 10372-06-05-0-92. Note: The X port to ISO Standard must not be machined. The X and Y ports of Moog valve body do not correspond to ISO Standard.

Surface to which valve is mounted requires a  $\sqrt{32}$  [ΔΔ] finish, flat within 0.001 [0.03] TIR.

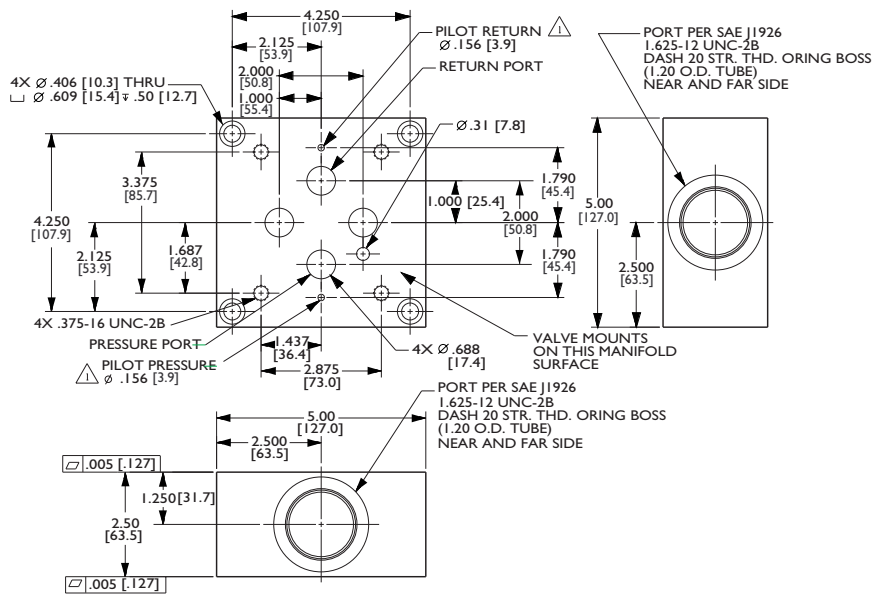
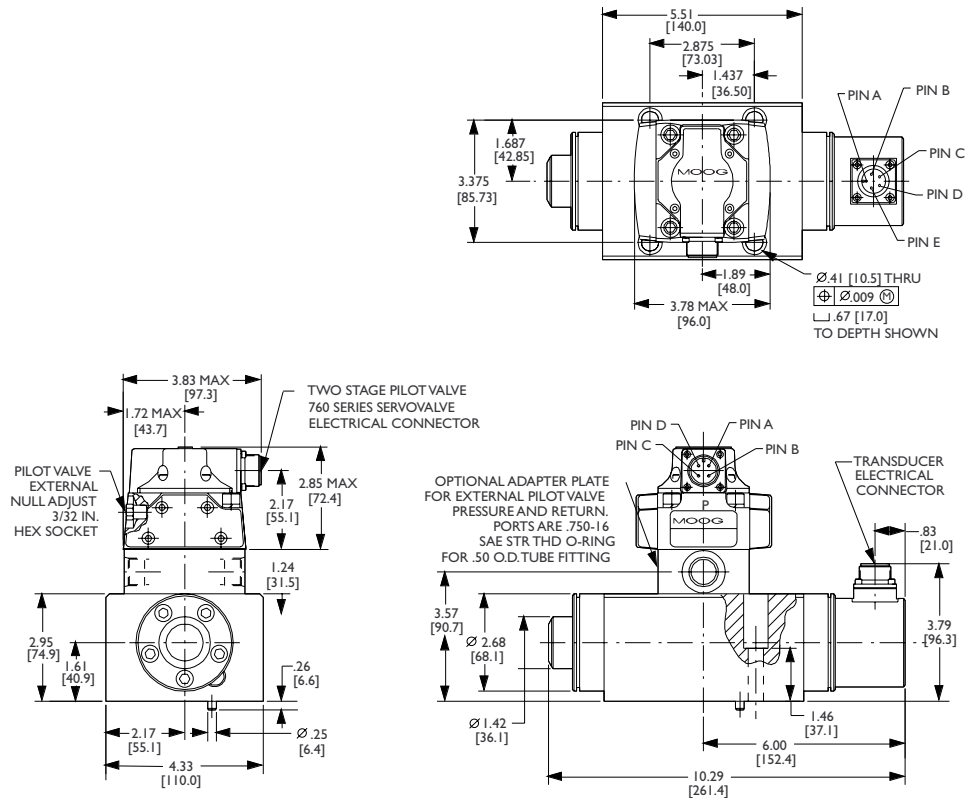

NOTES:  
 ▲ EXTERNAL PILOT SUPPLY AND RETURN PORTS SHOWN FOR REFERENCE ONLY. MANIFOLD P/N 22236AM3 IS NOT PROVIDED WITH PORTS.

79-1XXX SERIES  
TYPICAL SUBPLATE MANIFOLD

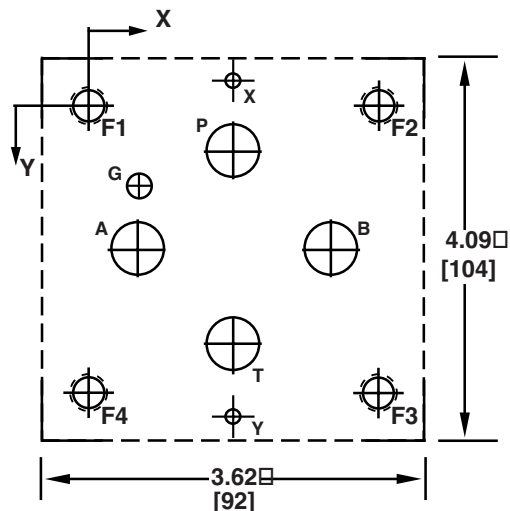

US	P	A	T	B	G	X*	Y*	F1	F2	F3	F4
	Ø.63	Ø.63	Ø.63	Ø.63	Ø.32	Ø.156	Ø.156	3/8-16	3/8-16	3/8-16	3/8-16
X	1.44	0.44	1.44	2.44	0.44	1.44	1.44	0	2.87	2.87	0
Y	0.69	1.69	2.69	1.69	0.94	-0.1	3.48	0	0	3.37	3.37

METRIC	P	A	T	B	G	X*	Y*	F1	F2	F3	F4
	Ø16	Ø16	Ø16	Ø16	Ø8	Ø4	Ø4	M10	M10	M10	M10
X	36,5	11,1	36,5	61,9	11,1	36,5	36,5	0	73	73	0
Y	17,5	42,9	68,3	42,9	23,8	-2,5	88,3	0	0	85,7	85,7

THE MOUNTING MANIFOLD MUST CONFORM TO ISO 10372-06-05-0-92

\* NOTE: The X port to the ISO standard must not be machined.

The X and Y ports of the Moog valve do **not** correspond to ISO standard.

Surface to which the valve is mounted requires a 32 finish [ΔΔ], flat within .0001 [.03] TIR.

SPARE PARTS AND ACCESSORIES FOR 79-1XXX SERIES

O-rings (included in delivery)											
for P, T, A, B	4 pieces	ID 0.800 x 0.070	42082-040								
for X, Y	2 pieces	ID 0.301 x 0.070	42082-012								
Mating connector, waterproof IP 65 (not included in delivery)		pilot valve	-49054F014S002S (MS3106F14S-2S)								
		LVDT	-49054F014S005S (MS3106F14S-5S)								
Flushing plate			G4321AM001								
Mounting bolts (not included in delivery)											
3/8 - 16 UNC x 2.25	4 pieces	required torque 50 lb.-ft.	A31324-336B								

79-2XXX SERIES (STANDARD)  
 INSTALLATION DRAWING  
 WITH PILOT VALVE 76X SERIES

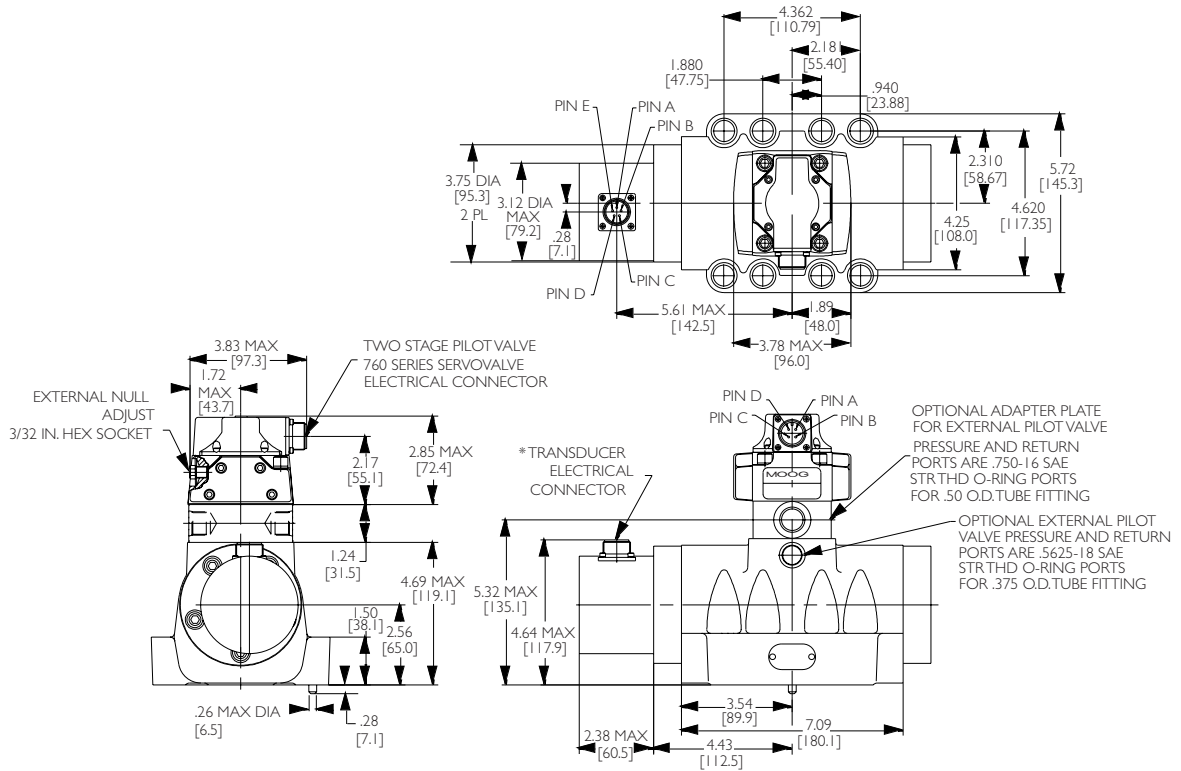

TYPICAL SUBPLATE MANIFOLD

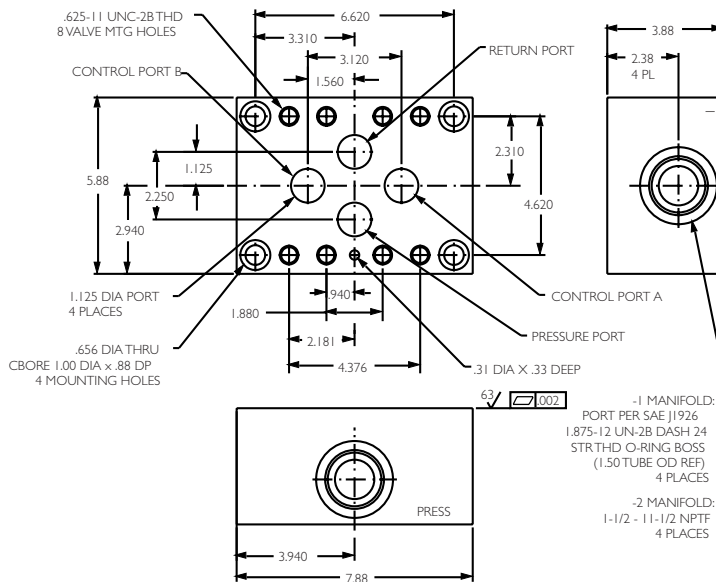

**Note:** The X and Y tubes have to be connected to the Moog valve body by fittings.

Surface to which valve is mounted requires a  $\sqrt{32}$  [AA] finish, flat within 0.001 [0.03] TIR.



# 79-2XXX SERIES (HIGH RESPONSE) INSTALLATION DRAWINGS WITH PILOT VALVES 76X SERIES

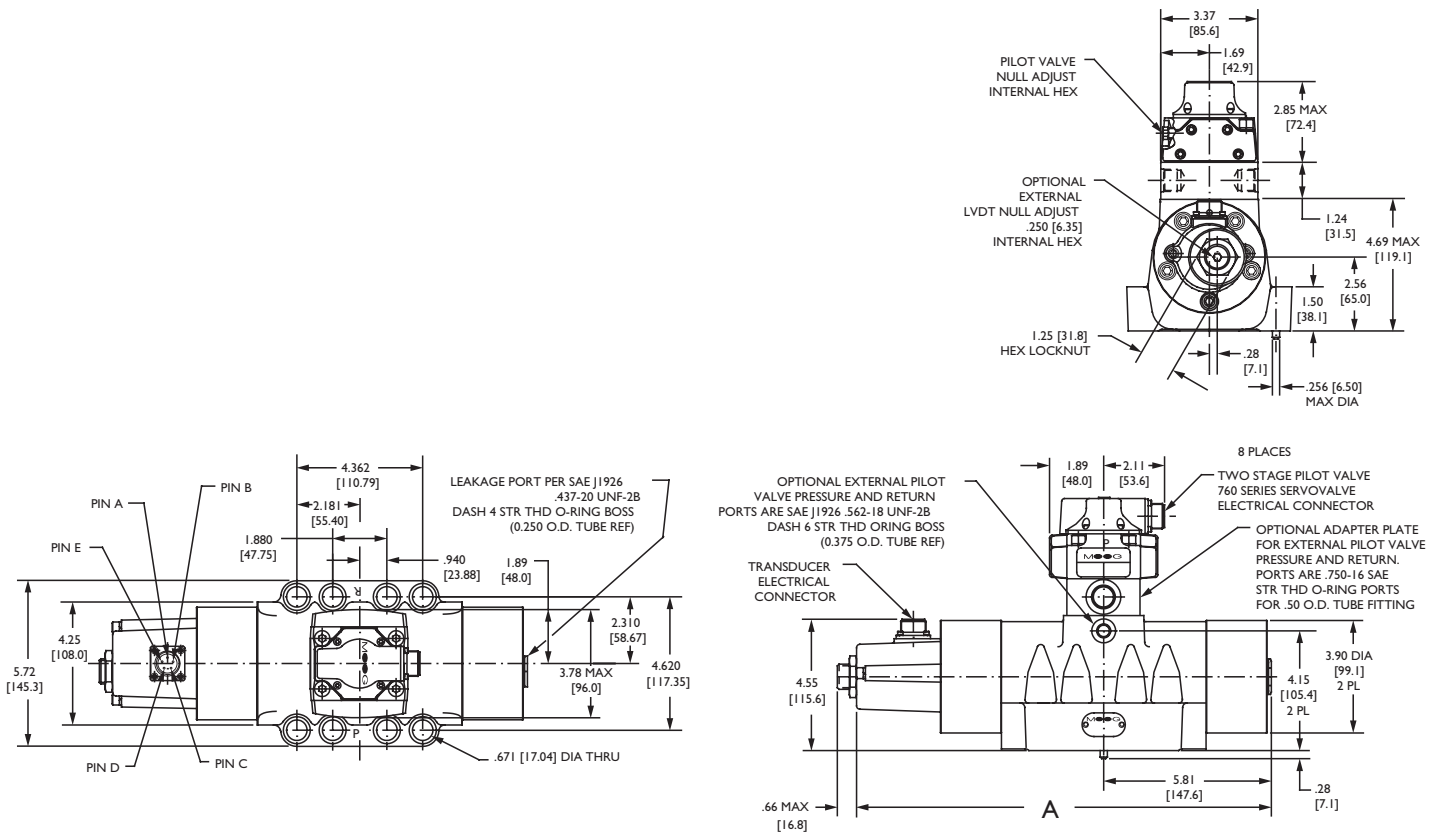

## SPARE PARTS AND ACCESSORIES FOR 79-2XXX SERIES

O-rings (included in delivery) for P, T, A, B	4 pieces	ID 1.418 x 0.138	42082-264
Mating connector, waterproof IP 65 (not included in delivery)		pilot valve	-49054F014S002S (MS3106FI4S-2S)
		LVDT	-49054F014S005S (MS3106FI4S-5S)
Flushing Block Kit			-43949-001K002
Mounting bolts (not included in delivery) 5/8 - 11 UNC x 2.25	8 pieces	required torque 215 lb.-ft.	B40052-218B

# 79 SERIES ELECTRICAL CONNECTIONS

## SET-UP AND OPERATION

### Servo Controller

The Moog Model NI21-132A is a convenient servo controller for use with 79 Series servo valves. The Model NI23-134 exciter/demodulator is available for operation of the spool position LVDT.

The AC excitation is adjustable between  $\pm 10$  and  $\pm 14$  volts peak-to-peak. The recommended frequency is 2000 Hz (NI23-134) to achieve good servo valve response; however, a lower frequency may be necessary if a long cable run is required.

The sensitivity of the spool position LVDT can be determined from Figure 1; the demodulated gain of the NI23-134 can be determined from its data sheet.

### Inner Loop Gain Set-up

- Connect the pilot valve coils to servo controller terminals 12 and 13 per the schematic below.
- Ground servo controller terminal 7 and apply a +1.0 VDC signal to servo controller terminal 6 (with the LVDT demodulated signal from the NI23-134 disconnected).
- Monitor the valve current by measuring the voltage drop across the 20  $\Omega$  sensing resistor R31 (test point lsv to TPI I). The valve current scale factor is 50 mA per volt measured at lsv.
- Adjust the GAIN 2 pot to obtain the desired servocontroller gain (see equations to the right). It may not be possible to operate with satisfactory valve stability at the maximum servo controller gain as both the pilot valve and LVDT have  $\pm 10\%$  gain tolerances. It is recommended that the servo controller gain be turned down the first time pressure is applied.

### Standard Electrical Configuration

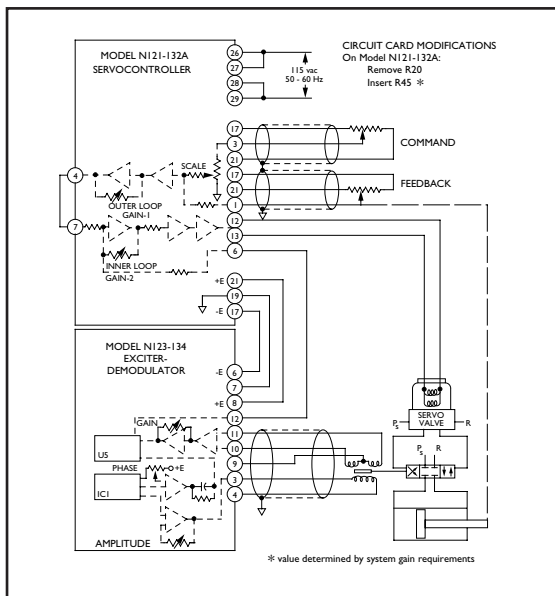

### Typical Valve Schematic\*

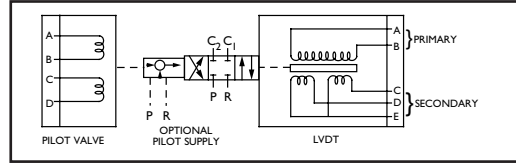

\*Refer to specific model installation for wiring details.

### Servo Valve Loop Gain

The inner loop gain of the 79 Series Servo Valves, when operating with 3,000 psi pilot supply pressure and with the pilot valve coils wired in parallel, can be determined by:

$$K_{IL} = \frac{K_A K_{PV} K_D K_X}{\Delta^X}$$

where:

- $K_{IL}$  = servo valve inner loop gain (sec<sup>-1</sup>)
- $K_A$  = servo controller gain (mA/VDC)
- $K_{PV}$  = pilot valve gain  $\left( \frac{\text{in}^3/\text{sec}}{\text{mA}} \right)$

$$= \frac{Z \text{ gpm} \times 3.85 \frac{\text{in}^3/\text{sec}}{\text{gpm}} \sqrt{\frac{3000 \text{ psi}}{1000 \text{ psi}}}}{15 \text{ mA}}$$

where Z = 2.5 for 79-100, 5.0 for 79-200 standard, and 4.0 for 79-200 High Response.

- $K_D$  = demodulator gain (VDC/vrms)
- $K_X$  = LVDT gain (vrms/inch)
- $\Delta^X$  = power spool end area = 1.107 in<sup>2</sup> for 79-200 standard  
= 0.442 in<sup>2</sup> for 79-200 High Response and 79-100

The required servo controller gain can be found by:

$$K_A = \frac{K_{IL} A^S}{K_{PV} K_D K_X}$$

### Outer Servo Loop Gain

The nominal gain of the 79 Series for the outer loop will be:

$$K_{VAL} = \frac{K^S}{K_D K_X}$$

where:

- $K_{VAL}$  = overall valve gain  $\left( \frac{\text{in}^3/\text{sec}}{\text{VDC}} \right)$
- $K^S$  = power spool flow gain (see specifications)
- $K_D$  = demodulator gain (VDC/vrms)
- $K_X$  = LVDT gain (vrms/inch)

Note that the power spool flow gain is specified for operation at 1000 psi supply. This gain must be corrected for operation at other supply pressures by multiplying it by a correction factor of the square root of the available hydraulic pressure divided by 1000 psi.

The summing section of the model NI21-132A servo controller can be used for summing the load servo command and feedback signals. The GAIN 1 pot provides a convenient loop gain adjustment.

# 79 SERIES ORDERING INFORMATION

## Model Number

79-1, 79-2    . . .

## Type Designation

. . . . .

Model Designation	
	Assigned at the factory

Valve Version	
S	Standard response
<b>H</b>	High response (200 only)

Rated Flow		
	Q <sup>n</sup> [gpm] at Δp <sup>n</sup> = 1,000 psi	
	Standard (gpm)	Series
10	30	(100 only)
25	60	(100 only)
40	100	(200 only)
80	200	(200 only)
99	260	(200 only)

Maximum Operating Pressure p <sub>o</sub> and Body Material	
F	3,000 psi
J	4,500 psi at p <sub>X</sub> ≤ 4,000 psi (X and Y external) operating pressure in ports P, A, B and T up to 5,000 psi possible
K	5,000 psi steel

Main Spool Type	
O	4-way / axis cut / linear characteristic
X	Special spool*
B	3 way/A port active

Pilot Stage	
P	76X Standard
Q	76X High response
<b>X</b>	76X Super high response

Valve Electronics	
7	Customer Supplied Electronics

Signal for 100% Spool Stroke		
Command		
H	±15 mA	(single coil)
L	±40 mA	(single coil)

LVDT Electrical Connector	
4	4 pin XDCR: 4 pin Pilot
5	5 pin XDCR: 4 pin Pilot

Seal Material	
V	FPM (Fluorocarbon)
	Others on request*

Pilot Connections and Pressure			
	Supply [X]	Return [Y]	
0	internal	internal	
1	external	internal	(adapter plate)
2	external	external	(adapter plate)
6	external	external	(ports in body)

Spool Position without Electrical Signal		
	Position	Pilot Pressure [psi]
O	Undefined	≥ 215
A	P ⇒ B, A ⇒ T	≥ 215
B	P ⇒ A, B ⇒ T	≥ 215

Preferred configurations highlighted.  
All combinations may not be available.  
Options may increase price and delivery.  
Technical changes are reserved.

\* Optional designs are available with special spool bushing lap configuration.  
Available seal materials: Fluorocarbon (Std.), BUNA or EPR.

# TAKE A CLOSER LOOK

Motion Control solutions from Moog are available around the world.  
For more information, visit our web site or contact one of the locations below.

Argentina  
+54 11 4326 5916  
info.argentina@moog.com

India  
+91 80 4057 6605  
info.india@moog.com

Singapore  
+65 677 36238  
info.singapore@moog.com

Australia  
+61 3 9561 6044  
info.australia@moog.com

Ireland  
+353 21 451 9000  
info.ireland@moog.com

South Africa  
+27 12 653 6768  
info.southafrica@moog.com

Brazil  
+55 11 3572 0400  
info.brazil@moog.com

Italy  
+39 0332 421 111  
info.italy@moog.com

Spain  
+34 902 133 240  
info.spain@moog.com

Canada  
+1 716 652 2000  
info.canada@moog.com

Japan  
+81 46 355 3767  
info.japan@moog.com

Sweden  
+46 31 680 060  
info.sweden@moog.com

China  
+86 21 2893 1600  
info.china@moog.com

Korea  
+82 31 764 6711  
info.korea@moog.com

Switzerland  
+41 71 394 5010  
info.switzerland@moog.com

Finland  
+358 9 2517 2730  
info.finland@moog.com

Luxembourg  
+352 40 46 401  
info.luxembourg@moog.com

United Kingdom  
+44 168 429 6600  
info.uk@moog.com

France  
+33 1 4560 7000  
info.france@moog.com

The Netherlands  
+31 252 462 000  
simulation@moog.com

USA  
+1 716 687 7600  
info.usa@moog.com

Germany  
+49 7031 622 0  
info.germany@moog.com

Norway  
+47 6494 1948  
info.norway@moog.com

Hong Kong  
+852 2 635 3200  
info.hongkong@moog.com

Russia  
+7 8 31 713 1811  
info.russia@moog.com

**[www.moog.com/industrial](http://www.moog.com/industrial)**

Moog is a registered trademark of Moog Inc. All trademarks as indicated herein are the property of Moog Inc. and its subsidiaries.  
©2011 Moog Inc. All rights reserved.

79 Series Servo Valve CDL6198 Rev. K 1211  
TJW/PDF