

MOOG

760 Series Installation and Operation Instruction

Electrohydraulic Servovalve

I. INTRODUCTION

This manual provides instructions and procedures necessary to install, operate and troubleshoot the Moog 760 Series Industrial Servovalve. Troubleshooting instructions are outlined so that only the specific component(s) suspected of failure may be identified.

2. OPERATION

The Moog 760 Series Industrial Servovalve consists of a polarized electrical torque motor and two stages of hydraulic power amplification. The motor armature extends into the air gaps of the magnetic flux circuit and is supported in this position by a flexure tube member. The flexure tube acts as a seal between the electromagnetic and hydraulic sections of the valve. The two motor coils surround the armature, one on each side of the flexure tube.

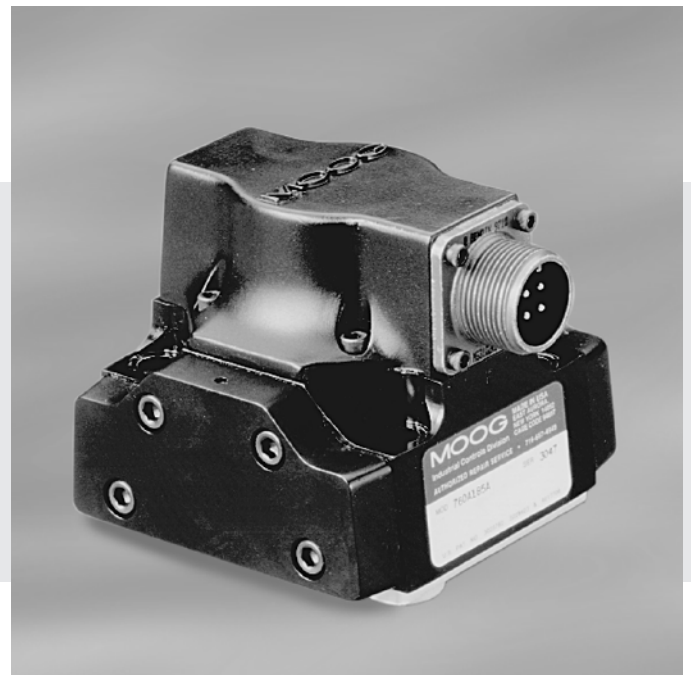

The flapper of the first stage hydraulic amplifier is rigidly attached to the midpoint of the armature. The flapper extends through the flexure tube and passes between two nozzles, creating two variable orifices between the nozzle tips and the flapper. The pressure controlled by the flapper and nozzle variable orifice is fed to the end areas of the second stage spool.

The second stage is a conventional 4-way spool design in which output flow from the valve, at a fixed valve pressure drop, is proportional to spool displacement from the null position. A cantilever feedback spring is fixed to the flapper and engages a slot at the center of the spool. Displacement of the spool deflects the feedback spring which creates a force on the armature/flapper assembly.

Input signal induces a magnetic charge in the armature and causes a deflection of the armature and flapper. This assembly pivots about the flexure tube and increases the size of one nozzle orifice and decreases the size of the other.

This action creates a differential pressure from one end of the spool to the other and results in spool displacement. The spool displacement causes a force in the feedback wire which opposes the original input signal torque. Spool movement continues until the feedback wire force equals the input signal force.

ELECTROHYDRAULIC VALVE CUT-AWAY

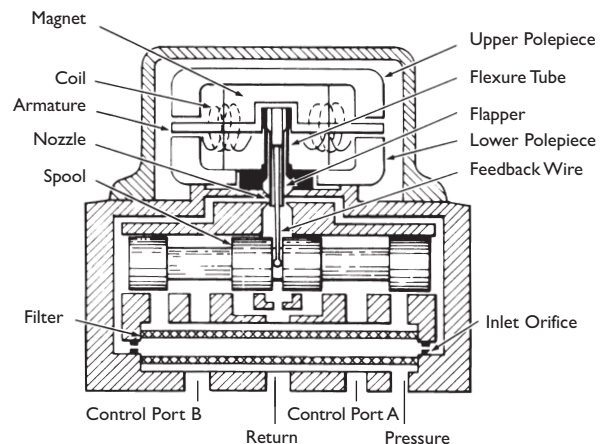

Figure 1 Moog Series 760

CAUTION

DISASSEMBLY, MAINTENANCE, OR REPAIR OTHER THAN IN ACCORDANCE WITH THE INSTRUCTIONS HEREIN OR OTHER SPECIFIC WRITTEN DIRECTIONS FROM MOOG WILL INVALIDATE MOOG'S OBLIGATIONS UNDER ITS WARRANTY.

3. HYDRAULIC SYSTEM PREPARATION

To prolong servovalve operational life and to reduce hydraulic system maintenance, it is recommended that the hydraulic fluid be kept at a cleanliness level of ISO DIS 4406 Code 16/13 maximum, 14/11 recommended. The most effective filtration scheme incorporates the use of a kidney loop or “off-line” filtration as one of the major filtration components. The filter for the “off-line” filtration scheme should be a $\beta_3 \geq 75$ filter for maximum effectiveness.

Upon system startup, and prior to mounting the servovalve, the entire hydraulic system should be purged of built-in contaminating particles by an adequate flushing. The servovalve should be replaced by a flushing manifold and the hydraulic circuit powered up under conditions of fluid temperature and fluid velocity reasonably simulating normal operating conditions. New system filters are installed during the flushing process whenever the pressure drop across the filter element becomes excessive. The flushing processes should turn over the fluid in the reservoir between fifty to one hundred times.

To maintain a clean hydraulic system, the filters must be replaced on a periodic basis. It is best to monitor the pressure drop across the filter assembly and replace the filter element when the pressure drop becomes excessive. In addition to other filters that are installed in the hydraulic circuit, it is recommended that a large capacity, low pressure $\beta_3 \geq 75$ filter be installed in the return line. This filter will increase the interval between filter element replacement and greatly reduce the system contamination level.

4. INSTALLATION

The Moog 760 Series Industrial Servovalve may be mounted in any position, provided the servovalve pressure, piston, and return ports match respective manifold ports.

The mounting pattern and port location of the servovalve is shown on figure 4. The servo-valve should be mounted with 5/16-18 x 1.75 inch long, socket head cap screws. Apply a light film of oil to the screw threads and torque to 96 inch pounds.

Wire mating connector for desired coil configuration and polarity. Thread connector to valve.

5. MECHANICAL NULL ADJUSTMENT

It is often desirable to adjust the flow null of a servovalve independent of other system parameters. The “mechanical null adjustment” on the Moog 760 Series servovalve allows at least $\pm 20\%$ adjustment of flow null.

The “mechanical null adjustor” is an eccentric bushing retainer pin, located above the “return” port designation on the valve body (see Figure 2) which, when rotated, provides control of the bushing position. Mechanical feedback elements position the spool relative to the valve body for a given input signal. Therefore, a movement of the bushing relative to the body changes the flow null.

Adjustment Procedure

Using a $\frac{3}{8}$ inch offset box wrench, loosen the self-locking fitting until the null adjustor pin can be rotated. (This should usually be less than 1/2 turn). DO NOT remove self-locking fitting. Insert a $\frac{3}{32}$ inch Allen wrench in null adjustor pin. Use the $\frac{3}{32}$ Allen wrench to rotate the mechanical null adjustor pin to obtain desired flow null. Torque self-locking fitting to 57 inch lbs.

Note:

Clockwise rotation of null adjustor pin produces open loop flow from port B to port A.

Tools and Equipment

- Blade screwdriver
- Allen wrench set ($\frac{3}{32}$, $\frac{3}{32}$, $\frac{1}{4}$ inch)
- No. 2-56 NC by 1- $\frac{1}{2}$ inch screw
- Torque wrenches (57 and 96 inch-pounds)
- $\frac{3}{8}$ inch offset box wrench
- Tweezers

Table 1. Replacement Parts

Part Description	Qty.	Part Number
760 Series Filter Replacement Kit	1	B52555RK004K001
Inlet Orifice - Body O-Ring (1)	2	-42082-059
Filter Plug - Body O-Ring (1)	2	-42082-060
End Cap - Bushing O-Ring (1)	2	-42082-042
End Cap - Body O-ring (1)	2	-42082-001
Filter Tube (1)	1	-23020
Base O-Rings	4	-42082-022

(1) Included in Filter Replacement Kit

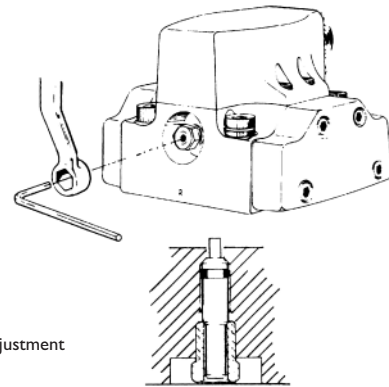

Figure 2
Mechanical Null Adjustment

6. GENERAL SERVICING RECOMMENDATIONS

- Disconnect the electrical lead to the servovalve.
- Relieve the hydraulic system of residual pressure.
- Remove the servovalve.

7. TROUBLESHOOTING CHART

The following troubleshooting chart lists potential troubles encountered, probable causes, and remedies.

Potential Trouble	Probable Cause	Remedy
Servo valve does not follow input command signal. (Actuator or components are stationary or creeping slowly).	1. Plugged inlet filter element.	1. Replace filter element.
High threshold. (Jerky, possible oscillatory or "hunting" motion in closed loop system).	1. Plugged filter element.	1. Replace filter element.
Poor response. (Servo valve output lags electrical command signal).	1. Partially plugged filter element.	1. Replace filter element. Check for dirty hydraulic fluid in system.
High Null Bias, (High input current required to maintain hydraulic cylinder or motor stationary).	1. Incorrect null adjustment. 2. Partially plugged filter element.	1. Readjust null. 2. Replace filter element and check for dirty hydraulic fluid in system.

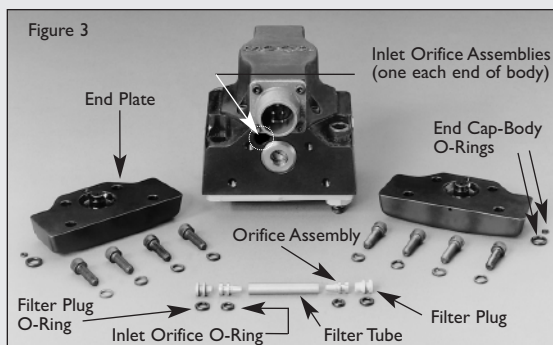

8. FILTER ASSEMBLY REPLACEMENT

- Remove eight socket head cap screws and lockwashers using a $\frac{5}{32}$ inch Allen wrench. Remove end caps.
- Remove O-Rings from end caps.
- Remove filter plug and inlet orifice assembly from both sides of body.
Note: 2-56 screw threads into the filter plug and inlet orifice assembly. Remove filter. The inlet orifice assemblies are matched to each other and are therefore interchangeable.
Note: These assemblies seat in body and cannot go through bore during removal.
- Remove O-Rings from filter plugs and O-Rings from inlet orifice assemblies.
- Visually inspect filter orifice assemblies for damage or foreign matter.
- Discard O-Rings and filters.
- Install O-Rings on filter plugs, and O-Rings on inlet orifices.
- Install filter, inlet orifice assembly, and a filter plug in body. Inlet orifice assembly pilots into filter. Install the other inlet orifice assembly and filter plug into other end of filter. Inlet orifice assemblies are interchangeable.
- Install O-Rings on end caps.
- Install end caps on body and install eight socket head cap screws and lockwashers. Torque the screws to 57 inch-pounds.

9. FUNCTIONAL CHECKOUT AND CENTERING

- Install servo valve on hydraulic system or test fixture, but do not connect electrical lead.
- Apply required system pressure to servo valve and visually examine for evidence of external leakage. If leakage is present and cannot be rectified by replacing O-Rings, remove the discrepant component and return for repair or replacement.
Note: If the system components are drifting or hardover, adjust the mechanical null of the servo valve.
- Connect electrical lead to servo valve and check phasing in accordance with system requirements.

10. AUTHORIZED REPAIR FACILITIES

Moog does not authorize any facilities other than Moog or Moog subsidiaries to repair its servo valves. It is recommended you contact Moog at (716) 652-2000 to locate your closest Moog repair facility. Repair by an independent (unauthorized) repair house will result in voiding the Moog warranty and could lead to performance degradation or safety problems.

760 SERIES INSTALLATION AND OPERATION INSTRUCTION

NOTES

1 Valve Weight:

1.1 lbs (0.5 kg)

2 Polarity:

A&C (+), B&D (-) produces flow out port B

3 Manifold O-Rings

0.070 (1.78) sect x 0.426 (10.82) I.D.
(Universal dash No. 13)

4 Surface:

Surface to which valve is mounted requires $\sqrt{32}$ finish, flat within .001 [0.025] TIR

5 Electrical Connector:

Mates with MS3106-14S-2S or equivalent

6 Null Adjust:

Flow out of port B will increase with clockwise rotations of null adjust pin

7 Compressed Oil Volume

for one control port: 0.229 in³
(3.75 cm³)

8 Suggested Mounting Screws:

0.312-18 x 1.750 lg (M8 x 45)
socket head screw (4 req'd)

Dimensions in parenthesis are in millimeters.

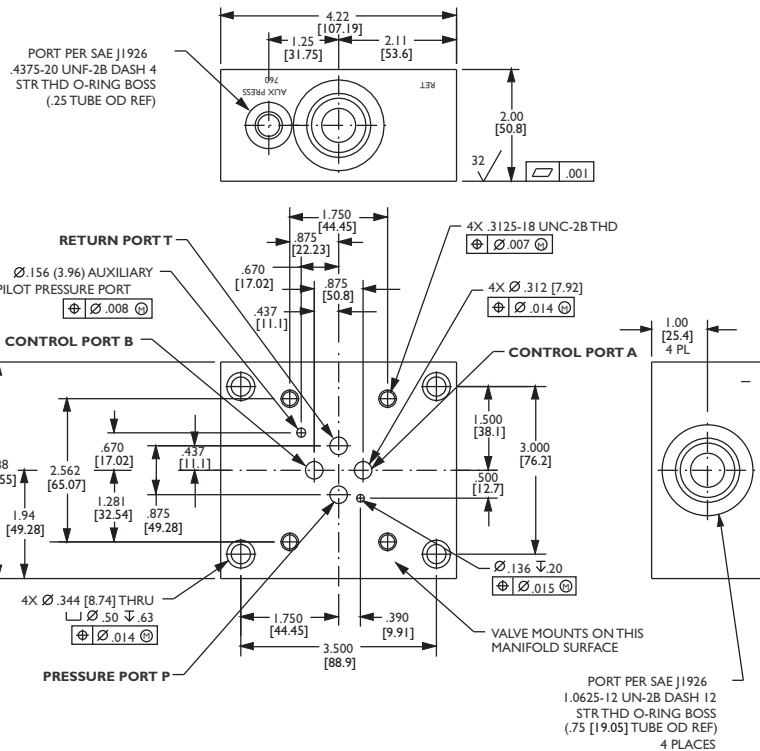
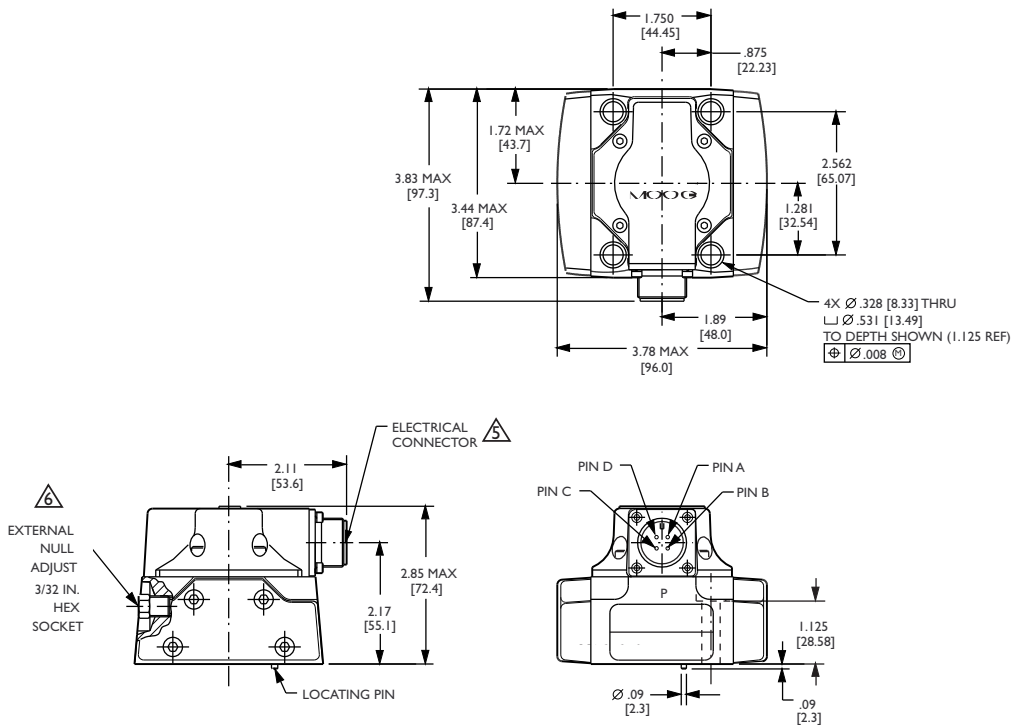

TYPICAL WIRING SCHEMATIC

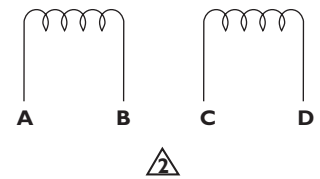

Figure 4

The products described herein are subject to change at any time without notice, including, but not limited to, product features, specifications, and designs.

MOOG
Industrial Controls Division
Moog Inc., East Aurora, NY 14052-0018
Telephone: +1-716-652-2000
Fax: +1-716-687-7910
Toll Free: +1-800-272-MOOG
www.moog.com/industrial